

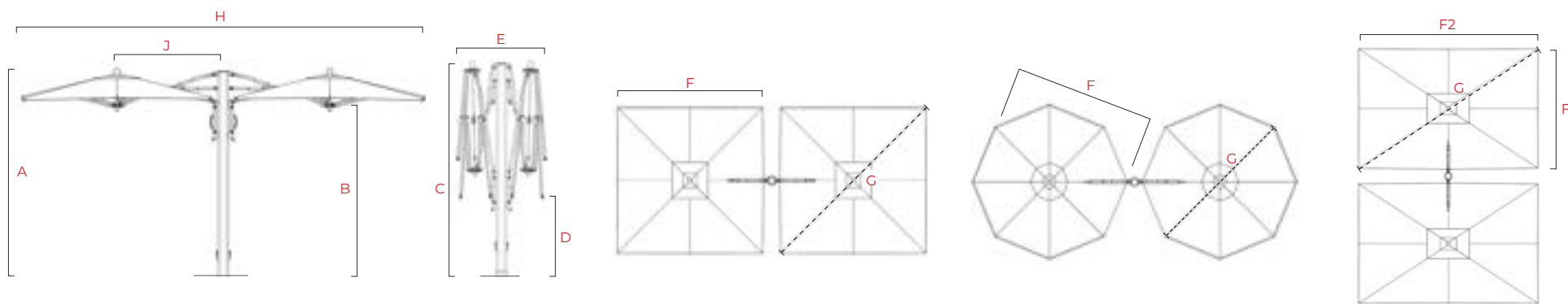

PRODUCT SPECIFICATIONS

OCEAN MASTER MAX CLASSIC DUAL CANTILEVER

LIFT SYSTEM: MANUAL PISTON ASSISTED LIFT



SHAPES		SQUARE		OCTAGON		RECTANGLE
SIZES (ft/cm)		8.0x16.0 / 245x490	10.0x20.0 / 305x610	9.0x180 / 275x540	11.0x22.0 / 340x680	16.0x12.0 / 490x365
A (in/cm)	MAST HEIGHT (open position)	109 / 277	108 / 274	107 / 272	108 / 274	108 / 274
B (in/cm)	CANOPY CLEARANCE	92 / 234	90 / 229	90 / 229	89 / 227	92 / 234
C (in/cm)	MAST HEIGHT (closed position)	109 / 277	108 / 274	107 / 272	108 / 274	108 / 274
D (in/cm)	TABLE CLEARANCE	39 / 98	21 / 54	43 / 109	31 / 79	22 / 56
E (in/cm)	PARASOL WIDTH (closed)	50 / 126	50 / 126	51 / 129	61 / 154	46 / 117
F (in/cm)	FLAT TO FLAT	96 / 244	120 / 305	101 / 257	124 / 314	F1 x F2: 97 x 145 / 245 x 368
G (in/cm)	POINT TO POINT	136 / 345	170 / 432	110 / 279	134 / 340	174 / 442
H (in/cm)	PARASOL WIDTH END-TO-END (open)	204 / 519	251 / 637	231 / 587	278 / 707	206 / 524
J (in/cm)	CENTER OF CANOPY (frame to center of base stem)	49 / 125	61 / 155	117 / 297	140 / 356	104 / 264

Dimension Tolerances ± 2" / 5cm. Dimensions shown are rounded to the nearest inch/cm and correspond to indicated lift system. Please check our 2D CAD-files for exact dimensions. Options are subject to change without notice.



PRODUCT SPECIFICATIONS

OCEAN MASTER MAX CLASSIC DUAL CANTILEVER

LIFT SYSTEM: EASYDRIVE CRANK

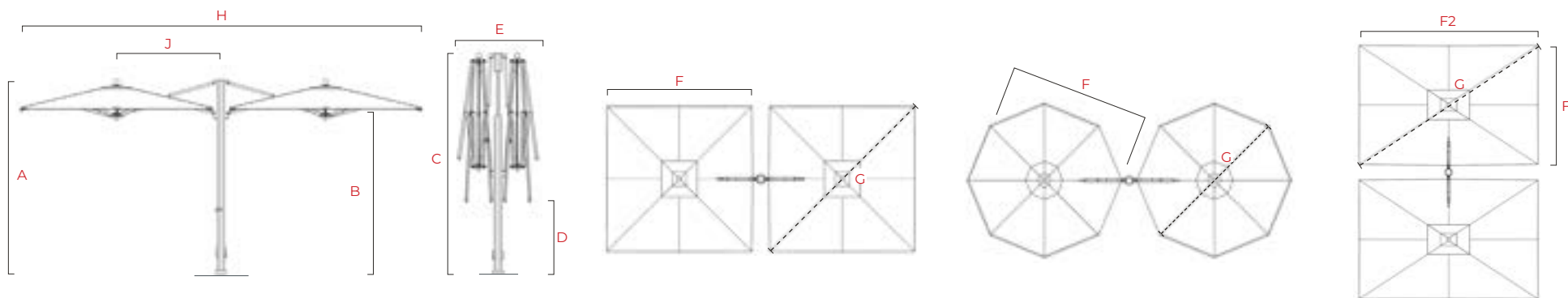

SHAPES		SQUARE				OCTAGON			RECTANGLE	
SIZES (ft/cm)		8.0x16.0 / 245x490	10.0x20.0 / 305x610	12.0x24.0 / 365x740	13.0x26.0 / 400x800	9.0x180 / 275x540	11.0x22.0 / 340x680	13.0x26.0 / 400x800	16.0x12.0 / 490x365	20.0x14.0 / 610x425
A (in/cm)	MAST HEIGHT (open position)	102 / 260	102 / 260	110 / 280	114 / 290	102 / 260	102 / 260	108 / 275	99 / 252	108 / 275
B (in/cm)	CANOPY CLEARANCE	90 / 229	87 / 221	89 / 225	92 / 234	88 / 223	82 / 208	86 / 219	85 / 216	93 / 237
C (in/cm)	MAST HEIGHT (closed position)	123 / 311	128 / 325	142 / 361	147 / 373	128 / 325	133 / 337	141 / 358	118 / 300	131 / 332
D (in/cm)	TABLE CLEARANCE	54 / 137	42 / 107	34 / 86	34 / 86	65 / 165	56 / 143	54 / 138	34 / 85	32 / 81
E (in/cm)	PARASOL WIDTH (closed)	50 / 127	48 / 122	52 / 132	55 / 139	48 / 122	50 / 127	55 / 140	47 / 120	48 / 122
F (in/cm)	FLAT TO FLAT	97 / 246	120 / 306	144 / 365	154 / 390	102 / 259	125 / 316	142 / 362	F1 x F2: 96 x 144 / 245 x 365	F1 x F2: 122 x 171 / 310 x 434
G (in/cm)	POINT TO POINT	137 / 348	170 / 433	203 / 516	217 / 551	110 / 280	135 / 342	154 / 391	173 / 440	210 / 533
H (in/cm)	PARASOL WIDTH END-TO-END (open)	205 / 521	251 / 638	300 / 762	319 / 811	231 / 586	279 / 709	320 / 813	205 / 522	254 / 646
J (in/cm)	CENTER OF CANOPY (frame to center of base stem)	53 / 135	65 / 165	75 / 191	80 / 203	61 / 154	72 / 183	83 / 211	54 / 138	66 / 168

Dimension Tolerances ± 2" / 5cm. Dimensions shown are rounded to the nearest inch/cm and correspond to indicated lift system. Please check our 2D CAD-files for exact dimensions. Options are subject to change without notice.



PRODUCT SPECIFICATIONS

OCEAN MASTER MAX CLASSIC DUAL CANTILEVER

LIFT SYSTEM: AUTOMATION (INCL. 2X AMBIA LED LIGHT & 4 HEATERS)

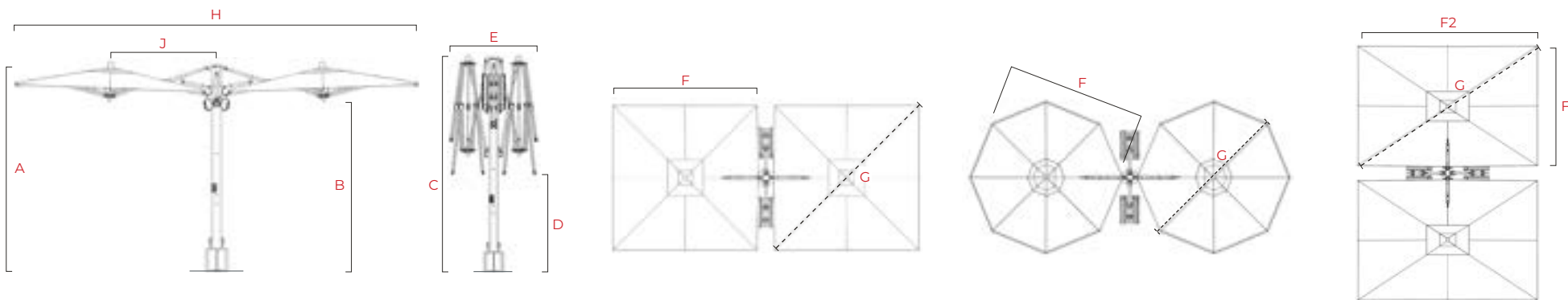

SHAPES		SQUARE				OCTAGON			RECTANGLE	
		8.0x16.0 / 245x490	10.0x20.0 / 305x610	12.0x24.0 / 365x740	13.0x26.0 / 400x800	9.0x18.0 / 275x540	11.0x22.0 / 340x680	13.0x26.0 / 400x800	16.0x12.0 / 490x365	20.0x14.0 / 610x425
A (in/cm)	MAST HEIGHT (open position)	104 / 264	104 / 264	110 / 279	114 / 290	104 / 264	104 / 264	114 / 290	101 / 257	108 / 275
B (in/cm)	CANOPY CLEARANCE	86 / 218	84 / 213	87 / 221	90 / 229	84 / 213	78 / 199	90 / 229	80 / 203	87 / 221
C (in/cm)	MAST HEIGHT (closed position)	124 / 315	130 / 330	142 / 361	147 / 372	129 / 328	134 / 341	141 / 358	119 / 302	131 / 333
D (in/cm)	TABLE CLEARANCE	56 / 142	44 / 110	34 / 85	34 / 85	55 / 139	57 / 145	54 / 137	35 / 89	32 / 80
E (in/cm)	PARASOL WIDTH (closed)	50 / 127	48 / 121	53 / 134	49 / 124	50 / 127	54 / 137	54 / 137	46 / 116	47 / 119
F (in/cm)	FLAT TO FLAT	96 / 245	120 / 305	144 / 365	154 / 391	102 / 259	125 / 316	142 / 362	F1 x F2: 97 x 145 / 245 x 368	F1 x F2: 122 x 171 / 309 x 435
G (in/cm)	POINT TO POINT	136 / 345	170 / 432	203 / 516	218 / 554	110 / 280	135 / 343	154 / 392	174 / 442	209 / 531
H (in/cm)	PARASOL WIDTH END-TO-END (open)	205 / 521	251 / 638	300 / 762	319 / 811	232 / 589	280 / 712	321 / 814	206 / 524	254 / 645
J (in/cm)	CENTER OF CANOPY (frame to center of base stem)	54 / 137	65 / 165	77 / 196	81 / 206	60 / 152	72 / 183	81 / 206	54 / 137	65 / 165

Dimension Tolerances ± 2" / 5cm. Dimensions shown are rounded to the nearest inch/cm and correspond to indicated lift system. Please check our 2D CAD-files for exact dimensions. Options are subject to change without notice.