

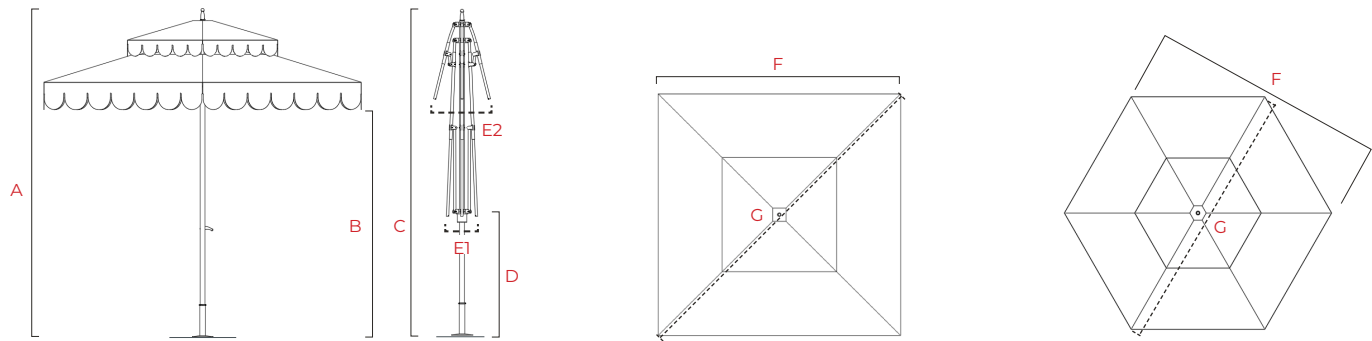

PRODUCT SPECIFICATIONS

OCEAN MASTER M1 CUPOLA



SHAPES		SQUARE		HEXAGON	
SIZES (ft/cm)		8.5 / 260	10.0 / 305	8.5 / 260	10.0 / 305
<b>A</b> (in/cm)	MAST HEIGHT (open)	120 / 295	117 / 312.4	113 / 277	114 / 279.4
<b>B</b> (in/cm)	CANOPY CLEARANCE	81 / 169	81 / 183	81 / 181	81 / 183
<b>C</b> (in/cm)	MAST HEIGHT (closed)	120 / 295	133 / 312.4	113 / 277	114 / 279.4
<b>D</b> (in/cm)	TABLE CLEARANCE	41 / 60	36 / 77	46 / 96	40 / 86
<b>E</b> (in/cm)	PARASOL WIDTH (closed)	E1: 20 / 60 E2: 27 / 68	E1: 18 / 68 E2: 29 / 87	E1: 10 / 25 E2: 18 / 46	E1: 10 / 25 E2: 19 / 48
<b>F</b> (in/cm)	FLAT TO FLAT	101 / 262	118 / 305	98 / 254	108 / 282
<b>G</b> (in/cm)	POINT TO POINT	143 / 370	168 / 432	113 / 292	125 / 325
(ft <sup>2</sup> /m <sup>2</sup> )	CANOPY AREA COVERAGE	73 / 6.8	100 / 9.3	59 / 5.5	74 / 6.9

Dimension Tolerances  $\pm 2'' / 5\text{cm}$ . Dimensions shown are rounded to the nearest inch/cm and correspond to indicated lift system. Please check our 2D CAD-files for exact dimensions. Options are subject to change without notice.