

NINIX

Design by Kris Van Puyvelde



NINIX SPECIFICATIONS

STANDARD / LIMITED / ON REQUEST

DINING CHAIR	
REF:	NNX 55T...
WEIGHT:	10 kg
INFO:	OPTIONAL TEAK ARMRESTS BRONZE FRAME INCLUDES OILED TEAK ARMRESTS

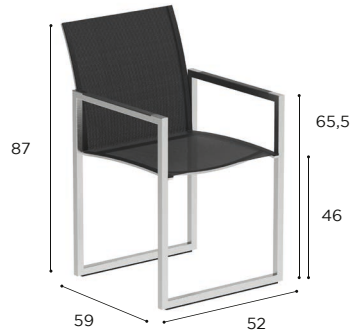

		BRUSHED STAINLESS STEEL	ELECTROPOLISHED STAINLESS STEEL	COATED STAINLESS STEEL				
		SS	EP	W	PB	S	BR	A
BATYLINE	WU	NNX 55 TWU	NNX 55 TEPWU	NNX 55 TWWU				
	CAU	NNX 55 TCAU	NNX 55 TEPCAU					
	PG				NNX 55 TPBPG	NNX 55 TSPG		
	ZU	NNX 55 TZU	NNX 55 TEPZU					NNX 55 TAZU
	GRP						NNX 55 TBRGRP	
NNX 55T ARWSET (TEAK ARMRESTS)								
CUSHIONS								
PIL NNX55T... (SEAT + BACK)								
CAT. A								
CAT. B								
CAT. C								

LOW CHAIR	
REF:	NNX 77T...
WEIGHT:	12 kg
INFO:	OPTIONAL TEAK ARMRESTS BRONZE FRAME INCLUDES OILED TEAK ARMRESTS

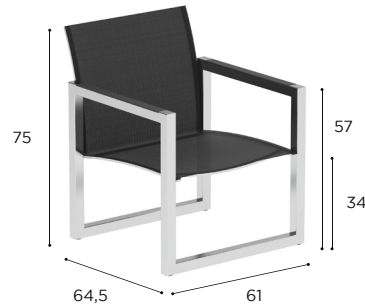

		BRUSHED STAINLESS STEEL	ELECTROPOLISHED STAINLESS STEEL	COATED STAINLESS STEEL				
		SS	EP	W	PB	S	BR	A
BATYLINE	WU	NNX 77 TWU	NNX 77 TEPWU	NNX 77 TWWU				
	CAU	NNX 77 TCAU	NNX 77 TEPCAU					
	PG				NNX 77 TPBPG	NNX 77 TSPG		
	ZU	NNX 77 TZU	NNX 77 TEPZU					NNX 77 TAZU
	GRP						NNX 77 TBRGRP	
NNX 77T ARWSET (TEAK ARMRESTS)								
CUSHIONS								
PIL NNX77T... (SEAT + BACK)								
CAT. A								
CAT. B								
CAT. C								

FOOTREST	
REF:	NNX FT...
WEIGHT:	9 kg



		BRUSHED STAINLESS STEEL	ELECTROPOLISHED STAINLESS STEEL	COATED STAINLESS STEEL				
		SS	EP	W	PB	S	BR	A
BATYLINE	WU	NNX F TWU	NNX F TEPWU	NNX F TWWU				
	CAU	NNX F TCAU	NNX F TEPCAU					
	PG				NNX F TPBPG	NNX F TSPG		
	ZU	NNX F TZU	NNX F TEPZU					NNX F TAZU
	GRP						NNX F TBRGRP	

NINIX SPECIFICATIONS

LOW BENCH	
REF:	NNX 154T...
WEIGHT:	27 kg
INFO:	OPTIONAL TEAK ARMRESTS BRONZE FRAME INCLUDES OILED TEAK ARMRESTS

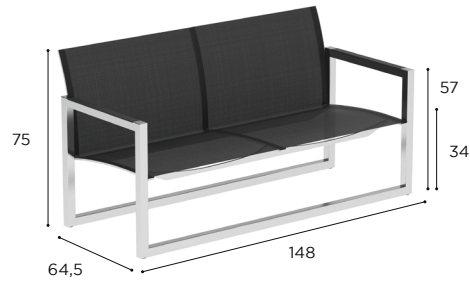

		BRUSHED STAINLESS STEEL	ELECTROPOLISHED STAINLESS STEEL	COATED STAINLESS STEEL				
		SS	EP	W	PB	S	BR	A
BAYLINE	WU	NNX 154 TWU	NNX 154 TEPWU	NNX 154 TWWU				
	CAU	NNX 154 TCAU	NNX 154 TEPCAU					
	PG				NNX 154 TPBPG	NNX 154 TSPG		
	ZU	NNX 154 TZU	NNX 154 TEPZU					NNX 154 TAZU
	GRP						NNX 154 TBRGRP	
NNX 154T ARWSET (TEAK ARMRESTS)								
CUSHIONS								
PIL NNX154T... (SEAT + BACK)								
CAT. A								
CAT. B								
CAT. C								

RELAX CHAIR	
REF:	NNX 60T...
WEIGHT:	12,5 kg
INFO:	HEADCUSHION INCLUDED OPTIONAL TEAK ARMRESTS BRONZE FRAME INCLUDES OILED TEAK ARMRESTS RECLINER WHEELS

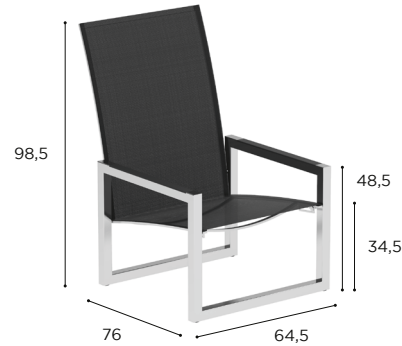

		BRUSHED STAINLESS STEEL	ELECTROPOLISHED STAINLESS STEEL	COATED STAINLESS STEEL				
		SS	EP	W	PB	S	BR	A
BAYLINE	WU	NNX 60 TWU	NNX 60 TEPWU	NNX 60 TWWU				
	CAU	NNX 60 TCAU	NNX 60 TEPCAU					
	PG				NNX 60 TPBPG	NNX 60 TSPG		
	ZU	NNX 60 TZU	NNX 60 TEPZU					NNX 60 TAZU
	GRP						NNX 60 TBRGRP	
NNX 60T ARWSET (TEAK ARMRESTS)								
CUSHIONS								
PIL NNX60T... (SEAT + BACK)								
CAT. A								
CAT. B								
CAT. C								

TOWEL RACK	
REF:	NNX TR...
WEIGHT:	9 kg

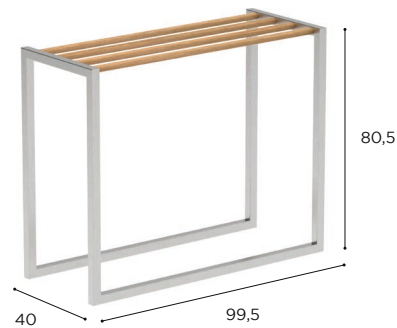

		BRUSHED STAINLESS STEEL	ELECTROPOLISHED STAINLESS STEEL	COATED STAINLESS STEEL				
		SS	EP	W	PB	S	BR	A
TEAK	W	NNX TR	NNX TR EP	NNX TR W	NNX TR PB	NNX TR S	NNX TR BR	NNX TR A

NINIX SPECIFICATIONS

STANDARD / LIMITED / ON REQUEST

BAR CHAIR	
REF:	NNX 43T...
WEIGHT:	11,8 kg
INFO:	OPTIONAL TEAK ARMRESTS BRONZE FRAME INCLUDES OILED TEAK ARMRESTS LOWERED FRAME ON REQUEST

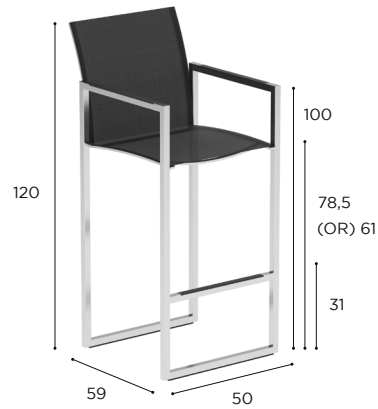

		BRUSHED STAINLESS STEEL	ELECTROPOLISHED STAINLESS STEEL	COATED STAINLESS STEEL				
		SS	EP	W	PB	S	BR	A
BATYLINE	WU	NNX 43 TWU	NNX 43 TEPWU	NNX 43 TWWU				
	CAU	NNX 43 TCAU	NNX 43 TEPCAU					
	PG				NNX 43 TPBPG	NNX 43 TSPG		
	ZU	NNX 43 TZU	NNX 43 TEPZU					NNX 43 TAZU
	GRP						NNX 43 TBRGRP	
NNX 43T ARWSET (TEAK ARMRESTS)								
CUSHIONS								
PIL NNX55T... (SEAT + BACK)								
CAT. A								
CAT. B								
CAT. C								
LOWERED FRAME (SURCHARGE)								

LOUNGER	
REF:	NNX 195T...
WEIGHT:	25 kg
INFO:	HEADCUSHION INCLUDED OPTIONAL TEAK ARMRESTS BRONZE FRAME INCLUDES OILED TEAK ARMRESTS PNEUMATIC RECLINER WHEELS



		BRUSHED STAINLESS STEEL	ELECTROPOLISHED STAINLESS STEEL	COATED STAINLESS STEEL				
		SS	EP	W	PB	S	BR	A
BATYLINE	WU	NNX 195 TWU	NNX 195 TEPWU	NNX 195 TWWU				
	CAU	NNX 195 TCAU	NNX 195 TEPCAU					
	PG				NNX 195 TPBPG	NNX 195 TSPG		
	ZU	NNX 195 TZU	NNX 195 TEPZU					NNX 195 TAZU
	GRP						NNX 195 TBRGRP	
NNX 195T ARWSET (TEAK ARMRESTS)								
CUSHIONS								
PIL NNX195T...								
CAT. A								
CAT. B								
CAT. C								

NINIX SPECIFICATIONS

SIDE TABLE	
REF:	NNX 50...
WEIGHT:	C: 10 kg W: 7,5 kg

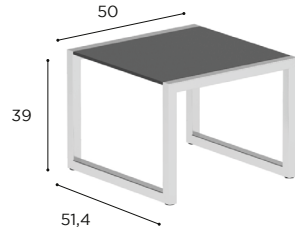

		BRUSHED STAINLESS STEEL	ELECTROPOLISHED STAINLESS STEEL	COATED STAINLESS STEEL					
		SS	EP	W	PB	S	BR	A	
CERAMIC	WU	NNX 50 CWU	NNX 50 CEPWU	NNX 50 CWWU	NNX 50 CPBWU	NNX 50 CSWU	NNX 50 CBRWU	NNX 50 CAWU	
	CD	NNX 50 CCD	NNX 50 CEPCD	NNX 50 CWCD	NNX 50 CPBCD	NNX 50 CSCD	NNX 50 CBRCD	NNX 50 CACD	
	CL	NNX 50 CCL	NNX 50 CEPCL	NNX 50 CWCL	NNX 50 CPBCL	NNX 50 CSCL	NNX 50 CBRCL	NNX 50 CACL	
	TR	NNX 50 CTR	NNX 50 CEPTR	NNX 50 CWTR	NNX 50 CPBTR	NNX 50 CSTR	NNX 50 CBRTR	NNX 50 CATR	
	TG	NNX 50 CTG	NNX 50 CEPTG	NNX 50 CWTG	NNX 50 CPBTG	NNX 50 CSTG	NNX 50 CBRTG	NNX 50 CATG	
	PG	NNX 50 CPG	NNX 50 CEPPG	NNX 50 CWPg	NNX 50 CPBPG	NNX 50 CSPG	NNX 50 CBRPG	NNX 50 CAPG	
	TS	NNX 50 CTS	NNX 50 CEPTS	NNX 50 CWTS	NNX 50 CPBTS	NNX 50 CSTS	NNX 50 CBRTS	NNX 50 CATS	
	TM	NNX 50 CTM	NNX 50 CEPTM	NNX 50 CWTM	NNX 50 CPBTM	NNX 50 CSTM	NNX 50 CBRTM	NNX 50 CATM	
	NM	NNX 50 CNM	NNX 50 CEPNM	NNX 50 CWNM	NNX 50 CPBNM	NNX 50 CSNM	NNX 50 CBRNM	NNX 50 CANM	
	ZU	NNX 50 CZU	NNX 50 CEPZU	NNX 50 CWZU	NNX 50 CPBZU	NNX 50 CSZU	NNX 50 CBRZU	NNX 50 CAZU	
	TEAK	W	NNX 50	NNX 50 EP	NNX 50 WW	NNX 50 WPB	NNX 50 WS	NNX 50 WBR	NNX 50 WA

LOW SIDE TABLE	
REF:	NNX 150T...
WEIGHT:	C: 48 kg W: 33 kg

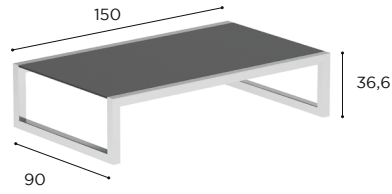

		BRUSHED STAINLESS STEEL	ELECTROPOLISHED STAINLESS STEEL	COATED ALUMINIUM					
		SS	EP	W	PB	S	BR	A	
CERAMIC	WU	NNX 150T CWU	NNX 150T CEPWU	NNX 150T CWWU	NNX 150T CPBWU	NNX 150T CSWU	NNX 150T CBRWU	NNX 150T CAWU	
	CD	NNX 150T CCD	NNX 150T CEPCD	NNX 150T CWCD	NNX 150T CPBCD	NNX 150T CSCD	NNX 150T CBRCD	NNX 150T CACD	
	CL	NNX 150T CCL	NNX 150T CEPCL	NNX 150T CWCL	NNX 150T CPBCL	NNX 150T CSCL	NNX 150T CBRCL	NNX 150T CACL	
	TR	NNX 150T CTR	NNX 150T CEPTR	NNX 150T CWTR	NNX 150T CPBTR	NNX 150T CSTR	NNX 150T CBRTR	NNX 150T CATR	
	TG	NNX 150T CTG	NNX 150T CEPTG	NNX 150T CWTG	NNX 150T CPBTG	NNX 150T CSTG	NNX 150T CBRTG	NNX 150T CATG	
	PG	NNX 150T CPG	NNX 150T CEPPG	NNX 150T CWPg	NNX 150T CPBPG	NNX 150T CSPG	NNX 150T CBRPG	NNX 150T CAPG	
	TS	NNX 150T CTS	NNX 150T CEPTS	NNX 150T CWTS	NNX 150T CPBTS	NNX 150T CSTS	NNX 150T CBRTS	NNX 150T CATS	
	TM	NNX 150T CTM	NNX 150T CEPTM	NNX 150T CWTM	NNX 150T CPBTM	NNX 150T CSTM	NNX 150T CBRTM	NNX 150T CATM	
	NM	NNX 150T CNM	NNX 150T CEPNM	NNX 150T CWNM	NNX 150T CPBNM	NNX 150T CSNM	NNX 150T CBRNM	NNX 150T CANM	
	ZU	NNX 150T CZU	NNX 150T CEPZU	NNX 150T CWZU	NNX 150T CPBZU	NNX 150T CSZU	NNX 150T CBRZU	NNX 150T CAZU	
	TEAK	W	NNX 150T	NNX 150T EP	NNX 150T WW	NNX 150T WPB	NNX 150T WS	NNX150T WBR	NNX 150T WA

TABLE	
REF:	NNX 90...
WEIGHT:	C: 37 kg W: 29 kg

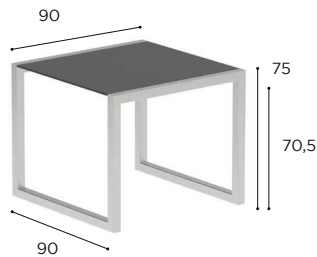

		BRUSHED STAINLESS STEEL	ELECTROPOLISHED STAINLESS STEEL
		SS	EP
CERAMIC	WU	NNX 90 CWU	NNX 90 CEPWU
	TG	NNX 90 CTG	NNX 90 CEPTG
	ZU	NNX 90 CZU	NNX 90 CEPZU
TEAK	W	NNX 90	NNX 90 EP

NINIX SPECIFICATIONS

STANDARD / LIMITED / ON REQUEST

BAR TABLE	
REF:	NNX 240H...
WEIGHT:	C: 52,8 kg

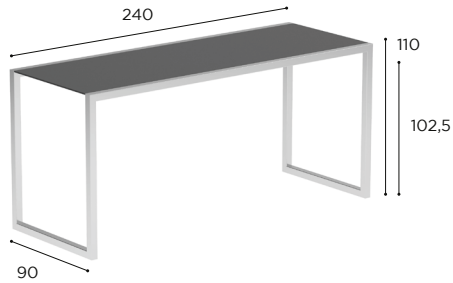

		BRUSHED STAINLESS STEEL	ELECTROPOLISHED STAINLESS STEEL	COATED STAINLESS STEEL					
		SS	EP	W	PB	S	BR	A	
CERAMIC	WU	NNX 240H CWU	NNX 240H CEPWU	NNX 240H CWWU	NNX 240H CPBWU	NNX 240H CSWU	NNX 240H CBRWU	NNX 240H CAWU	
	CD	NNX 240H CCD	NNX 240H CEPCD	NNX 240H CWCD	NNX 240H CPBCD	NNX 240H CSCD	NNX 240H CBRCD	NNX 240H CACD	
	CL	NNX 240H CCL	NNX 240H CEPCL	NNX 240H CWCL	NNX 240H CPBCL	NNX 240H CSCCL	NNX 240H CBRCL	NNX 240H CACL	
	TR	NNX 240H CTR	NNX 240H CEPTR	NNX 240H CWTR	NNX 240H CPBTR	NNX 240H CSTR	NNX 240H CBRTR	NNX 240H CATR	
	TG	NNX 240H CTG	NNX 240H CEPTG	NNX 240H CWTG	NNX 240H CPBTG	NNX 240H CSTG	NNX 240H CBRTG	NNX 240H CATG	
	PG	NNX 240H CPG	NNX 240H CEP PG	NNX 240H CWPG	NNX 240H CPBPG	NNX 240H CSPG	NNX 240H CBRPG	NNX 240H CAPG	
	TS	NNX 240H CTS	NNX 240H CEPTS	NNX 240H CWTS	NNX 240H CPBTS	NNX 240H CSTS	NNX 240H CBRTS	NNX 240H CATS	
	TM	NNX 240H CTM	NNX 240H CEPTM	NNX 240H CWTM	NNX 240H CPBTM	NNX 240H CSTM	NNX 240H CBRTM	NNX 240H CATM	
	NM	NNX 240H CNM	NNX 240H CEPNM	NNX 240H CWNM	NNX 240H CPBNM	NNX 240H CSNM	NNX 240H CBRNM	NNX 240H CANM	
	ZU	NNX 240H CZU	NNX 240H CEPZU	NNX 240H CWZU	NNX 240H CPBZU	NNX 240H CSZU	NNX 240H CBRZU	NNX 240H CAZU	
	TEAK	W	NNX 240H W	NNX 240H WEP	NNX 240H WW	NNX 240H WPB	NNX 240H WS	NNX 240H WBR	NNX 240H WA

LOW SIDE TABLE	
REF:	NNX 90T...
WEIGHT:	C: 32 kg W: 24 kg

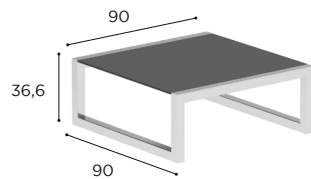

		BRUSHED STAINLESS STEEL	ELECTROPOLISHED STAINLESS STEEL	COATED ALUMINIUM					
		SS	EP	W	PB	S	BR	A	
CERAMIC	WU	NNX 90T CWU	NNX 90T CEPWU	NNX 90T CWWU	NNX 90T CPBWU	NNX 90T CSWU	NNX 90T CBRWU	NNX 90T CAWU	
	CD	NNX 90T CCD	NNX 90T CEP CD	NNX 90T CWCD	NNX 90T CPBCD	NNX 90T CSCD	NNX 90T CBRCD	NNX 90T CACD	
	CL	NNX 90T CCL	NNX 90T CEPCL	NNX 90T CWCL	NNX 90T CPBCL	NNX 90T CSCCL	NNX 90T CBRCL	NNX 90T CACL	
	TR	NNX 90T CTR	NNX 90T CEPTR	NNX 90T CWTR	NNX 90T CPBTR	NNX 90T CSTR	NNX 90T CBRTR	NNX 90T CATR	
	TG	NNX 90T CTG	NNX 90T CEPTG	NNX 90T CWTG	NNX 90T CPBTG	NNX 90T CSTG	NNX 90T CBRTG	NNX 90T CATG	
	PG	NNX 90T CPG	NNX 90T CEP PG	NNX 90T CWPG	NNX 90T CPBPG	NNX 90T CSPG	NNX 90T CBRPG	NNX 90T CAPG	
	TS	NNX 90T CTS	NNX 90T CEPTS	NNX 90T CWTS	NNX 90T CPBTS	NNX 90T CSTS	NNX 90T CBRTS	NNX 90T CATS	
	TM	NNX 90T CTM	NNX 90T CEPTM	NNX 90T CWTM	NNX 90T CPBTM	NNX 90T CSTM	NNX 90T CBRTM	NNX 90T CATM	
	NM	NNX 90T CNM	NNX 90T CEPNM	NNX 90T CWNM	NNX 90T CPBNM	NNX 90T CSNM	NNX 90T CBRNM	NNX 90T CANM	
	ZU	NNX 90T CZU	NNX 90T CEPZU	NNX 90T CWZU	NNX 90T CPBZU	NNX 90T CSZU	NNX 90T CBRZU	NNX 90T CAZU	
	TEAK	W	NNX 90T	NNX 90T EP	NNX 90T WW	NNX 90T WPB	NNX 90T WS	NNX 90T WBR	NNX 90T WA

TABLE	
REF:	NNX 150...
WEIGHT:	C: 53 kg W: 38 kg

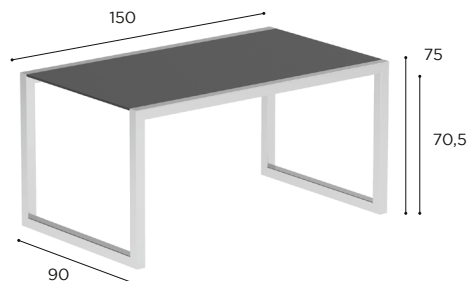

		BRUSHED STAINLESS STEEL	ELECTROPOLISHED STAINLESS STEEL
		SS	EP
CERAMIC	WU	NNX 150 CWU	NNX 150 CEPWU
	TG	NNX 150 CTG	NNX 150 CEPTG
	ZU	NNX 150 CZU	NNX 150 CEPZU
TEAK	W	NNX 150	NNX 150 EP

EXTENDABLE TABLE	
REF:	NNX 270...
WEIGHT:	80 kg
INFO:	EXTENDABLE WHEELS

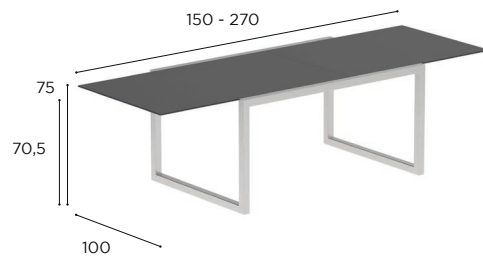

		BRUSHED STAINLESS STEEL	ELECTROPOLISHED STAINLESS STEEL	COATED STAINLESS STEEL				
		SS	EP	W	PB	S	BR	A
CERAMIC	WU	NNX 270 CWU *	NNX 270 CEPWU *	NNX 270 CWWU *	NNX 270 CPBWU *	NNX 270 CSWU *	NNX 270 CBRWU *	NNX 270 CAWU *
	PG	NNX 270 CPG *	NNX 270 CEP PG *	NNX 270 CWPG *	NNX 270 CPBPG *	NNX 270 CSPG *	NNX 270 CBRPG *	NNX 270 CAPG *
	ZU	NNX 270 CZU *	NNX 270 CEPZU *	NNX 270 CWZU *	NNX 270 CPBZU *	NNX 270 CSZU *	NNX 270 CBRZU *	NNX 270 CAZU *

EXTENDABLE TABLE	
REF:	NNX 360...
WEIGHT:	C: 132 kg W: 83 kg
INFO:	EXTENDABLE WHEELS

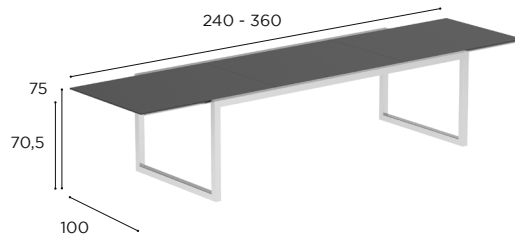

		BRUSHED STAINLESS STEEL	ELECTROPOLISHED STAINLESS STEEL	COATED STAINLESS STEEL				
		SS	EP	W	PB	S	BR	A
CERAMIC	WU	NNX 360 CWU	NNX 360 CEPWU	NNX 360 CWWU	NNX 360 CPBWU	NNX 360 CSWU	NNX 360 CBRWU	NNX 360 CAWU
	PG	NNX 360 CPG	NNX 360 CEP PG	NNX 360 CWPG	NNX 360 CPBPG	NNX 360 CSPG	NNX 360 CBRPG	NNX 360 CAPG
	ZU	NNX 360 CZU	NNX 360 CEPZU	NNX 360 CWZU	NNX 360 CPBZU	NNX 360 CSZU	NNX 360 CBRZU	NNX 360 CAZU
TEAK	W	NNX 360	NNX 360 EP	NNX 360 WW	NNX 360 WPB	NNX 360 WS	NNX 360 WBR	NNX 360 WA